

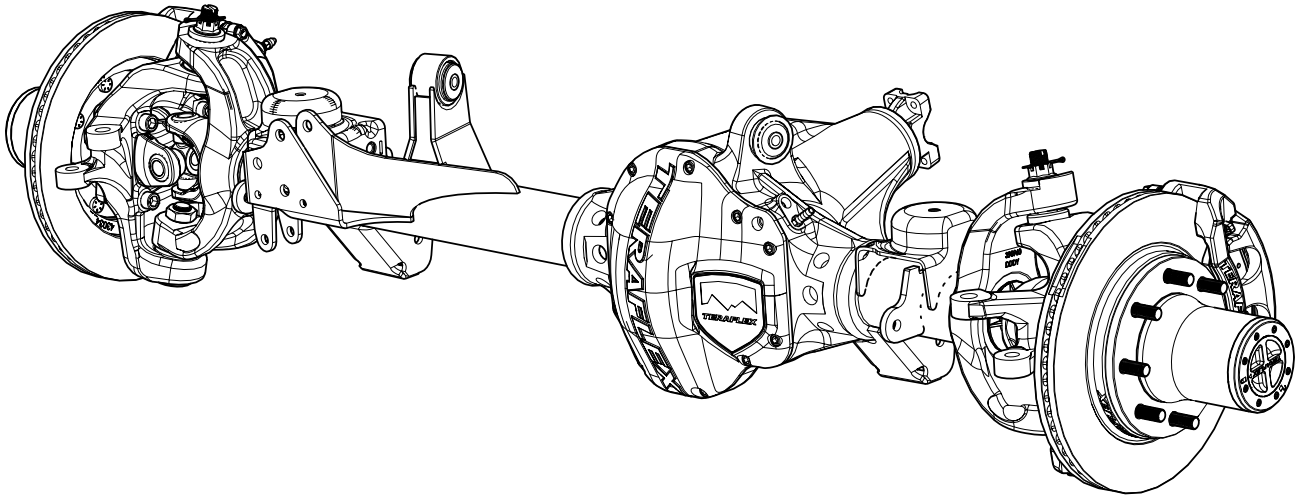

# JK CRD60 Front Fixed Spindle Conversion Kit

www.teraflex.com

Kit # 3060000 JK CRD60 Front Fixed Spindle Conversion Kit



## Important Notes:

Prior to beginning this or any installation read these instructions to familiarize yourself with the required steps and evaluate if you are experienced and capable to personally perform these modifications. A factory service manual should be used in conjunction with these installation instructions.

**This kit requires new wheels with an 8 on 6.5" bolt pattern.**

**CRD60 Axles pre April 2011** may not have our newest brake mounts. Those with the older style of brake mount will need to purchase two of the **994920 Front JK Big Brake Caliper Mounts on D60 Knuckles**.

This kit is intended to be used with your current brake calipers and it can be used with your current brake pads, however, **new brake pads are recommended** when ever new rotors are installed. (For the Teraflex JK Front Big Brake Semi-Metallic Pads & Clips order Part # 4303430)

## Tools needed:

- Basic mechanics tool set
- One Ton Spindle Nut Socket
- Blue thread locking compound

Parts List- Kit #3060000			
Item No.	Part No.	Description	QTY.
1	300848	Full Float Axle Spindle Front with ABS for JK CRD60	2
2	550	Bolt M14-1.5 x 80mm Long Grade 12.9 Cap Screw	8
3	3000865	Full Float Front Hub with 8 on 6.5" Bolt Pattern	2
4	2000005	TJ/YJ Full Float Hub Seal 836S	2
5	200450	TONE RING, 52 TEETH, JK FULL FLOAT	2
6	800950	JK Full Float Hub Seal to Protect Speed Sensor	2
7	601449	Bearing Cup and Cone CRD60 Full Float Inner	2
8	601455	Bearing SET38 CRD60 Full Float Outer	2
9	8373	Nut Spindle Dana 60 Inner Spicer #660568	2
10	8371	Washer Front Axle Spicer #621028	2
11	8372	Nut Spindle Dana 60 Outer Spicer #621027	2
12	4303417	JK Front Passenger SLOTTED 13.3" Big Brake Rotor (8 on 6.5)	1
13	4303418	JK Front Driver SLOTTED 13.3" Big Brake Rotor (8 on 6.5)	1
14	610218	Wheel Stud 9/16"-18 x 2" Long	16
15	300612	CRD60 Front Axle Stub Shaft with 35 Spline for Fixed Spindle Conversion with Seal Spacer	2
16	3449350	Slimlock Locking Hub for 35 Spline Shaft, Pair	1
17	3070014	Spindle Bearing and Seal Kit for Dan60 Full Float Hubs	2

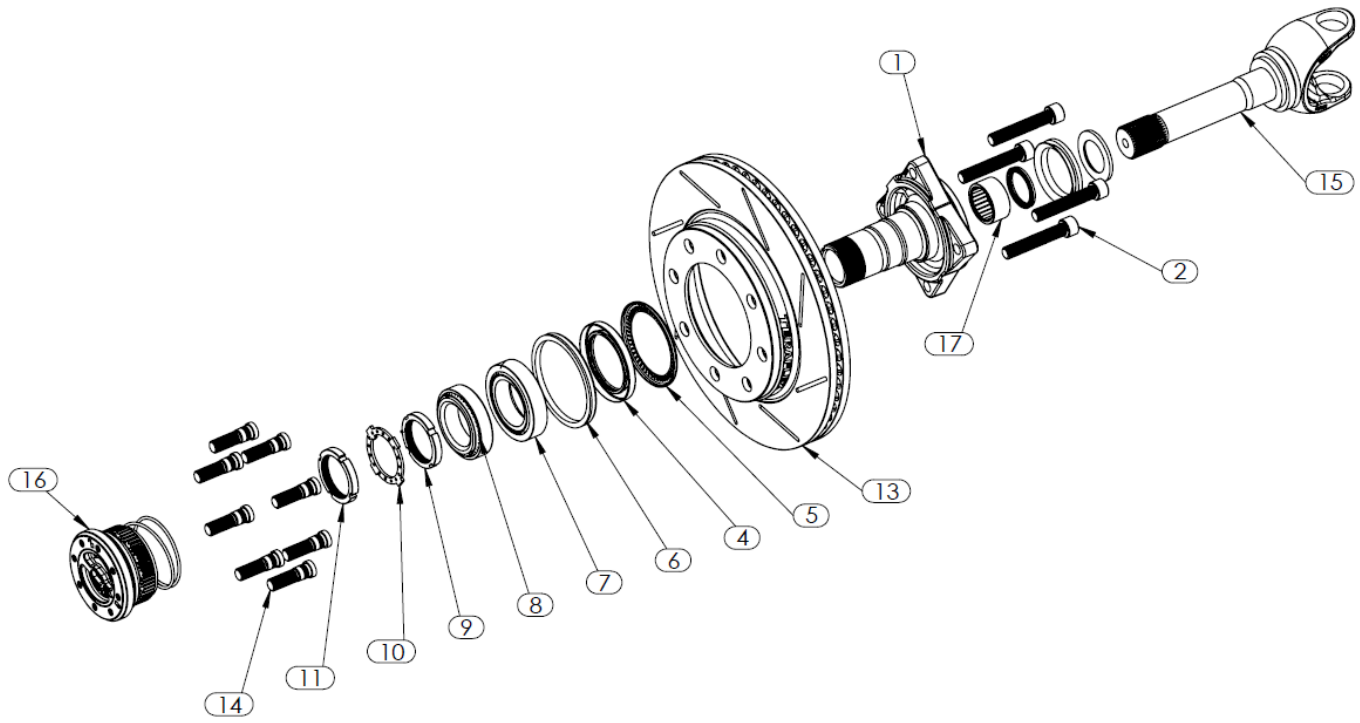

Refer to the factory service manual for lift locations. Raise and support the vehicle. Remove the tires and wheels and support the axle with a jack or jack stands.

1

Drain the front differential.  
Hint: It will help to remove one side of the tie rod and drag link. Doing so will make the knuckle easier to turn and allow quicker access to bolts on the knuckles and differential cover.

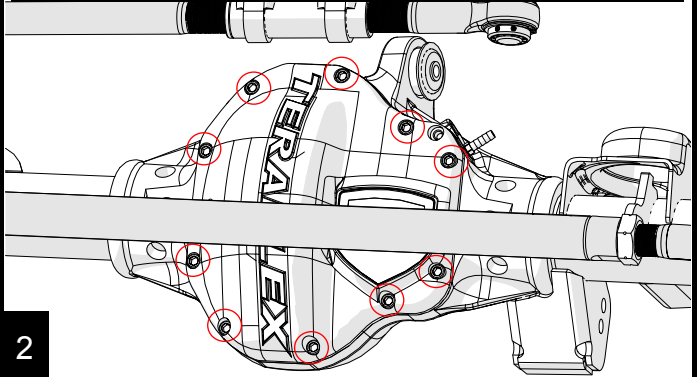

2

Remove the caliper and brake pad assembly using a 14 mm and 17 mm end wrench to hold the sleeve. Carefully secure the calipers to the frame to prevent brake line damage.

Remove the anchor bracket using a 21 mm.

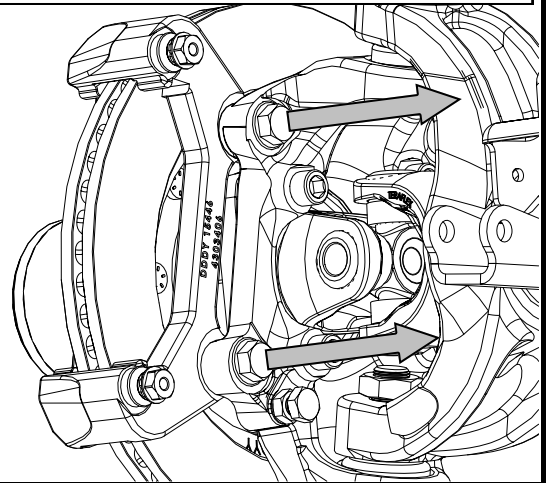
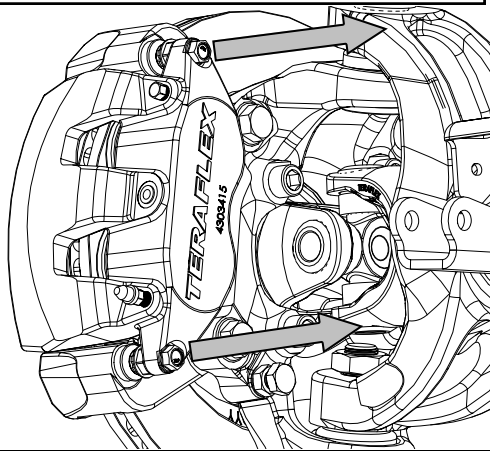

3

4

Loosen and remove the 36 mm or 1 3/8" axle nut, rotor clips, and the rotor.

With a 12mm Allen, **loosen** the four unit bearing retainer bolts. **Begin to pull the unit bearing, dust shield, and axle shaft as an assembly, but do not completely remove.**  
Hint: Turn the knuckle back and forth for bolt access.

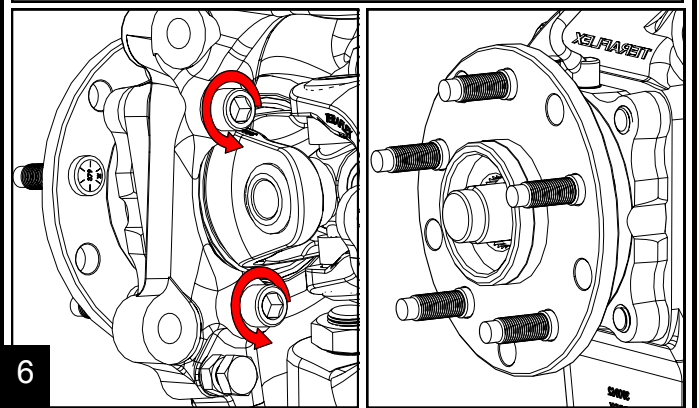
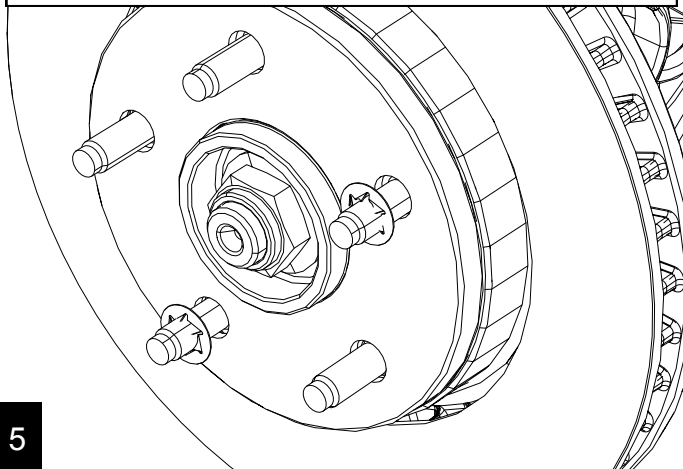

5

6

With the unit bearing loose and slightly separated, remove the wheel speed sensor with a 5mm allen wrench. Use care to prevent damaging the sensor and wiring.

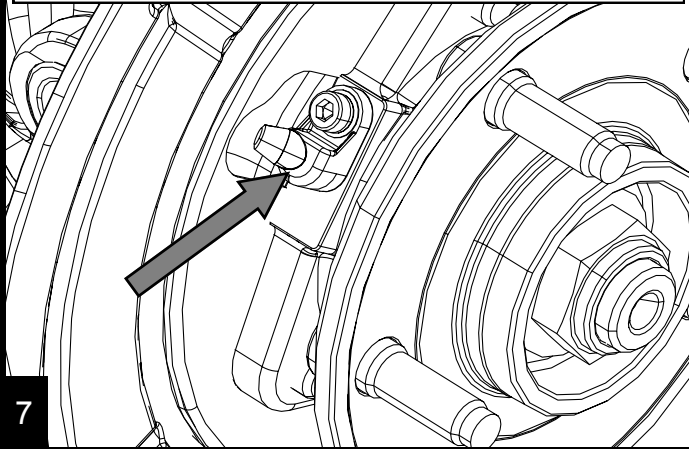

Next, finish pulling the unit bearing assembly off the stub shaft and set the dust shield aside. **Support the axle as it slides out to prevent inner seal damage.**

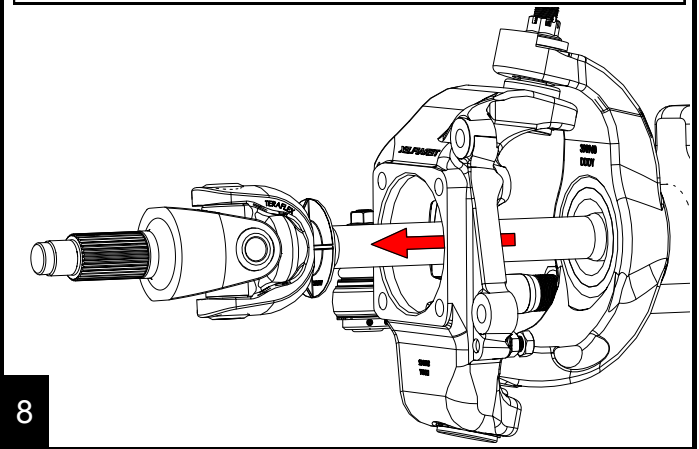

Remove the factory stub shaft from the inner axle shaft at the u-joint. Remove the inner c-clips, then press the two u joint caps from the yoke of the stub shaft with the use of a ball joint press or similar tool. Repeat process on the inner shaft and discard the u joint.

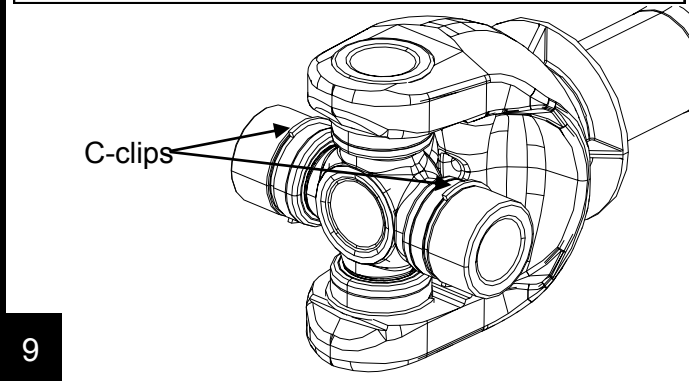

Install the new u joint and 35 spline stub shaft by pressing the u joint caps back into place and replacing the c-clips.

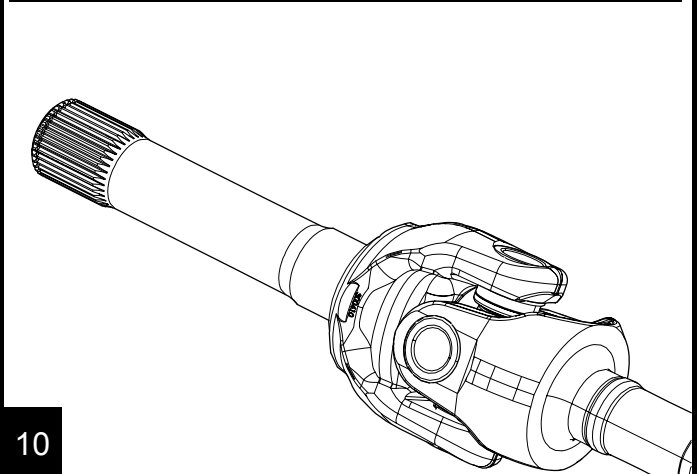

Install the stub shaft seal and thrust washer. Carefully slide the spindle bearing seal over the splines to reduce the risk of damage to the seal. **Note the orientations of the washer and seals!** The chamfered edge of the washer faces the yoke. The stub shaft seal installs with the flare facing away from the yoke.

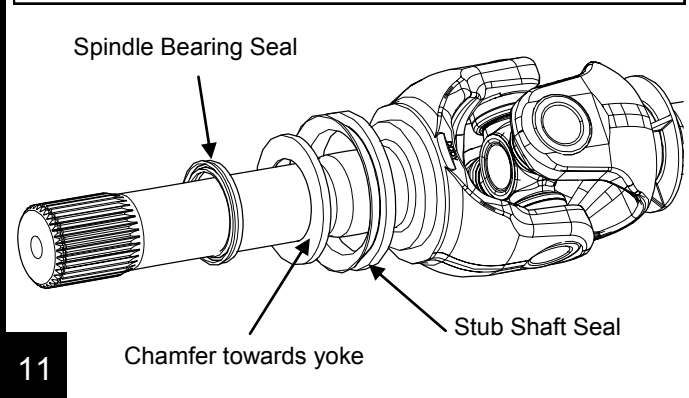

Pack the spindle bearing with grease and press it into the spindle. (Press in until it bottoms in bore.) Orient the bearing with the open end facing in and the rolled end facing out.

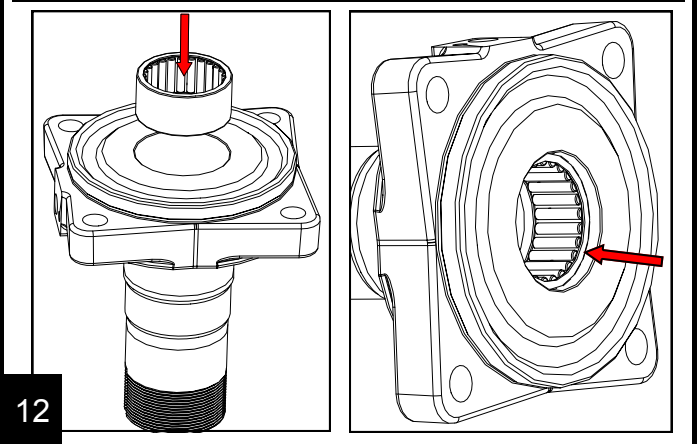

Slide the axle shaft back into the housing, while supporting the inner shaft to avoid spline contamination and inner axle seal damage.

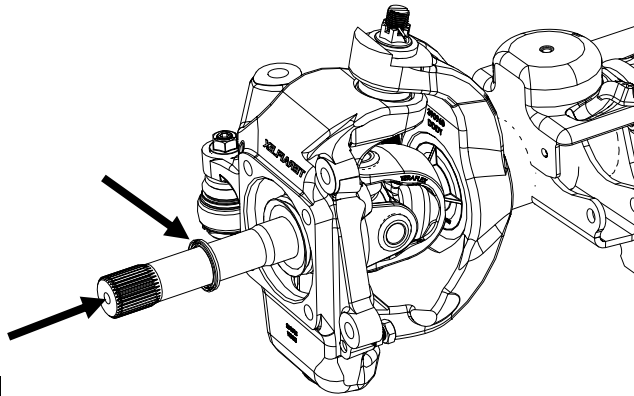

13

Slide the dust shield into place and install the spindle onto the stub shaft. Carefully seat the spindle bearing seal into the back of the spindle. Note the orientation of the seal!

**Note: The spindle bearing seal is installed in this way to reduce the risk of seal damage. If the seal is inserted into the spindle before install, the seal may become nicked or unseated, reducing the effectiveness of the seal.**

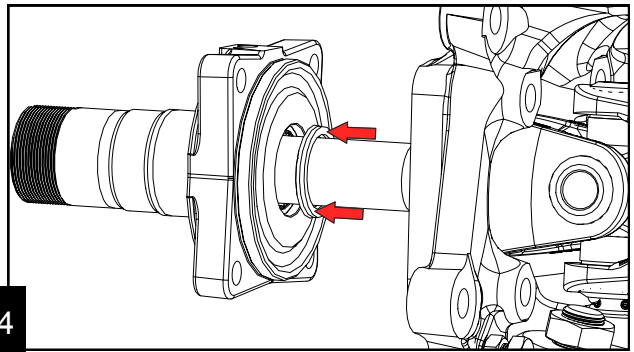

14

Loosely install the spindle into the bore of the outer knuckle and install the speed sensor. Use care to prevent damage to the sensor and wiring. Torque the bolt to **34-50 in-lbs. (4-6 Nm)**. Apply blue thread locking compound to spindle bolts and torque to **75 ft-lbs. (102 Nm)**.

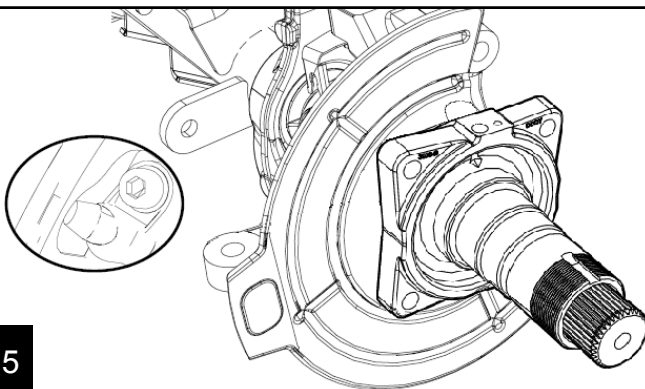

15

It is important to pack each of the bearings with plenty of wheel bearing grease. Also coat the races, spindle, inner surfaces of the hub and seals with grease.

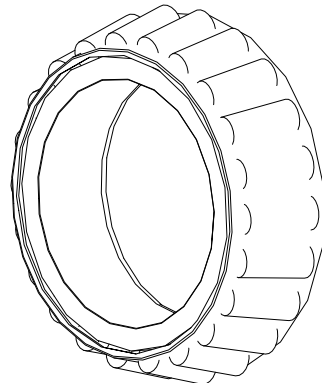

16

Grease and install the wheel speed sensor seal. Note the orientation of the seal.

**Note: It is critical all seals are greased. Failure to grease all seals will result in premature seal failure!**

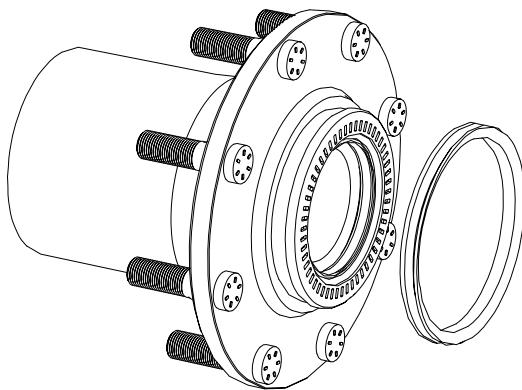

17

Slide the hub assembly over the spindle and install the outer bearing. **Install the inner lock nut with the pin facing out.**

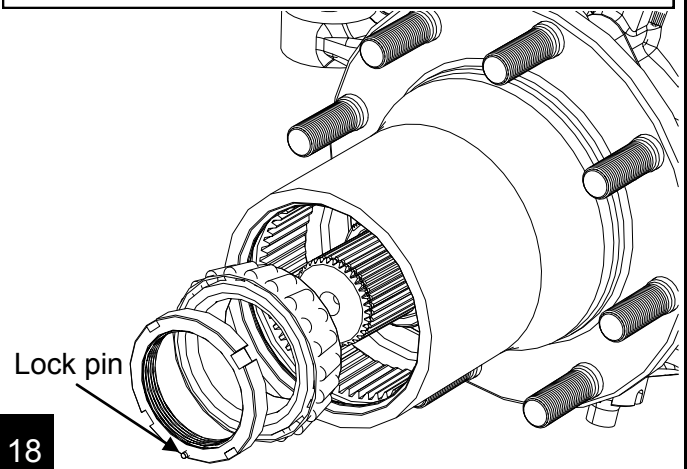

18

While turning the hub, torque the inner lock nut to **50 ft-lbs (68 Nm)** to seat the bearing, then **back the nut off 90 degrees (1/4 turn)**. **Tighten** the nut as necessary to achieve pin alignment to the washer.

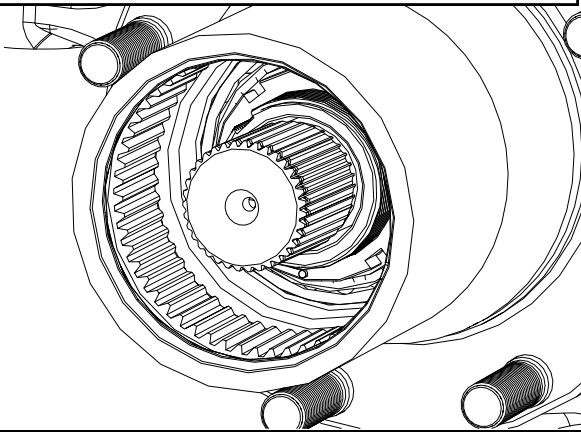

19

Install the lock washer. Note: the hole pattern of the lock washer is offset with the keyway to provide half-position settings by flipping the washer over.

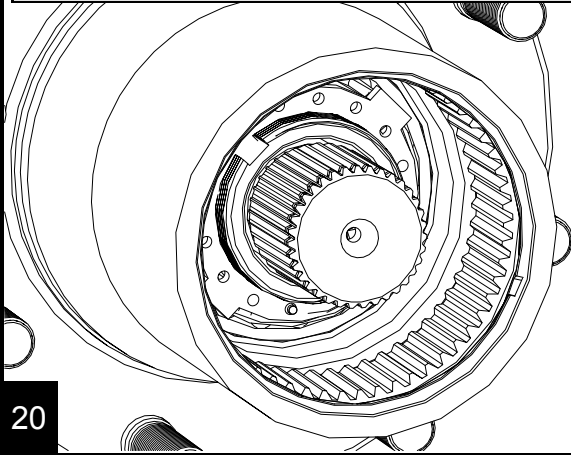

20

Install the outer lock nut. Torque to **160-205 ft-lbs (217-278 Nm)**.

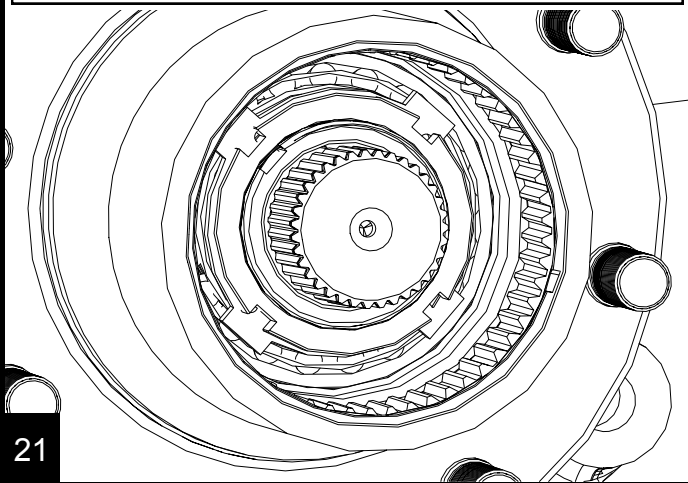

21

Install the TeraFlex SlimLock Locking Hubs (See 999214 SlimLock Hub Installation included with locking hub kit)

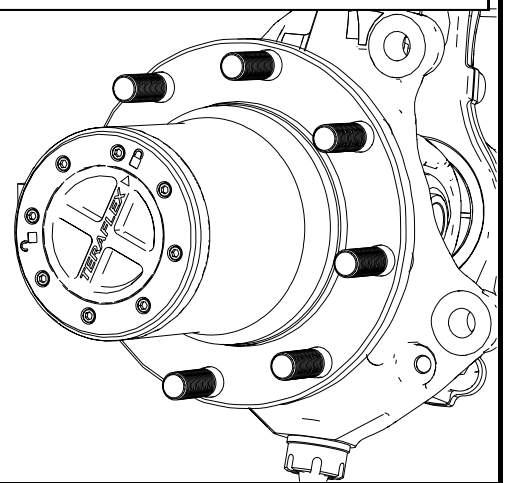

22

Install the new rotors. Slots should be oriented as shown, with opposite side mirrored.

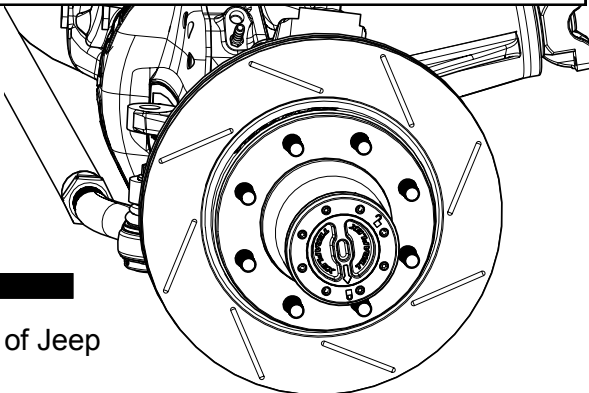

Front of Jeep

23

Front Left Brake Rotor

Reinstall the anchor bracket mounts onto the knuckle using the factory 21mm bolts. Apply a small amount of blue thread lock to bolts. Torque to **120 ft-lbs (163 Nm)**

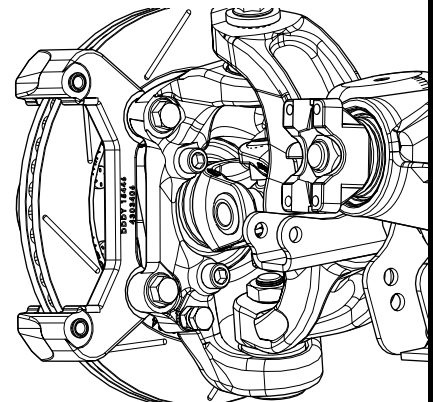

24

Install brake pads into the anchor bracket mounts.

**Note:** Your old pads will work with this kit, however, replacement of pads is recommend when a new rotor is installed. Use a Piston Brake Caliper Compressor Tool to press the pistons back into the caliper. (*Refer to Service Manual*)

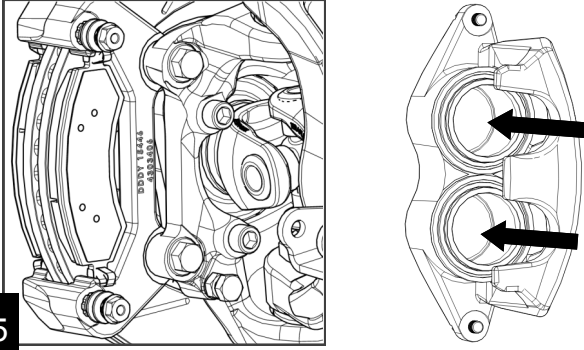

25

Install caliper onto the brake anchor bracket.

**Hint:** Install the lower bolt loosely, then rotate the caliper upward while holding the brake pads tight against the rotor.

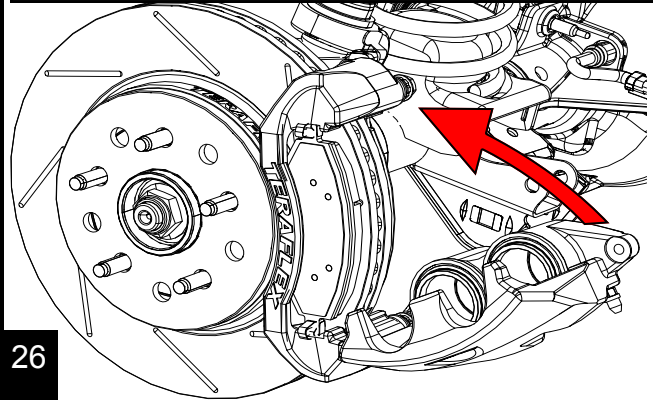

26

Apply a small amount of blue thread lock to bolts  
Torque to 26 ft-lbs (35 Nm)

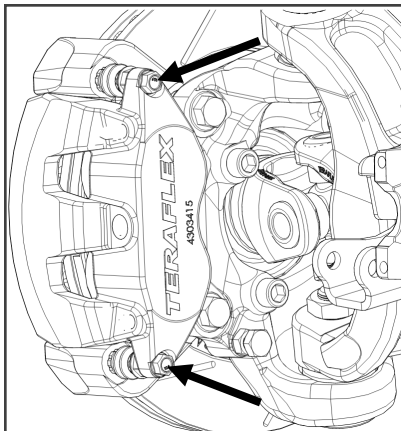

27

With both sides of the axle complete, install the tires using the provided lug nuts. Torque the lug nuts to **135 ft-lbs (180 Nm)**. Remove supports and lower to the ground. Refill the differential with high quality **80W90 gear oil**.

Re-check fluid level after approximately 15 miles of driving. Re-torque the lug nuts after 100 miles of driving.

**Note:** After an offroad excursion, involving water crossings or heavy mudding, it is always good practice to check the differentials and hubs for water/mud contamination. Service axle as required.

Wheel bearing service intervals can be timed with brake maintenance.

## PRODUCT INFORMATION

### MAINTENANCE INFORMATION:

It is the buyer's responsibility to have all suspension, drivetrain, steering, and other components checked for proper tightness and torque after the first 100 miles and every 3000 miles after that.

### NOTICE TO INSTALLER:

The enclosed "Warning to Driver" sticker must be installed in the vehicle in driver's view. This sticker is to act as a constant safety reminder when operating the vehicle. It is your responsibility as the equipment installer to install the provided sticker and to forward the product instructions to the vehicle's owner for review. If a "Warning to Driver" sticker or product installation guide were not included in the kit, FREE replacement stickers and instructions are available by request. It is the installer's duty to ensure a safe and controllable vehicle after the modifications have been performed.

### WARNING:

Neither the seller nor the manufacturer will be liable for any loss, damage, or injury directly or indirectly arising from the use of or inability to determine the use of these products. Before using, the user shall determine the suitability of the products for its intended use, and the user shall assume all responsibility and risk in connection therewith.

### WARNING TO DRIVER:

This vehicle has been modified to enhance off road performance and has unique handling characteristics. Use in harsh environments can cause extreme stress on the components. Vehicle should be inspected after being off road to make sure that all the components are in working order and safe to travel on the highway. All fasteners should be checked so that they are at the correct torque specifications as the vibration and stresses from off roading may cause critical fasteners to work loose. Extra care should be taken to inspect the critical components, steering, and brake systems. During each oil change components such as arms, tie rod ends, etc should be greased and checked for excessive wear. Any worn components should be replaced. When returning to the pavement always set or restore tire air pressure to the factory recommendation and connect or engage any disabled sway bar mechanisms. Because of the higher center of gravity and larger tires, this vehicle handles and reacts differently than many passenger cars, both on and off road. You must drive it safely! Extreme care should be taken to prevent vehicle rollover or loss of control, which can result in serious injury or death. Avoid sudden sharp turns or abrupt maneuvers. Generally, braking performance and capabilities are decreased when significantly larger/heavier tires are used, especially when used in combination with transfer case low-range reduction kits. Take this into consideration while driving. Do not add, alter or fabricate any factory or aftermarket parts to increase vehicle height over the intended height of the TeraFlex product purchased. Mixing component brand is not recommended. TeraFlex Inc. will not be responsible for any altered product or any improper installation or use of our products. We will be happy to answer any questions concerning the design, function, and correct use of our products. It is ultimately the buyer's responsibility to have all bolts/nuts checked for tightness after the first 100 miles and then every 3000 miles. Wheel alignment, steering system, suspension and drive line systems must be inspected by a qualified professional mechanic at least every 3000 miles.

### TERAFLEX PRODUCT WARRANTY:

TeraFlex Inc. warrants TeraFlex Suspension products to the original retail purchaser to be free of defects in material and workmanship for as long as the original purchaser owns the vehicle on which products were originally installed.

Failure to complete regular maintenance (grease every 3000 miles) on TeraFlex FlexArms will void this warranty. All other conditions of the standard TeraFlex product warranty apply.

All TeraLow products are covered by the TeraFlex two (2) year warranty to be free of defects in material and workmanship for two years from date purchased.

TeraFlex axles are covered by a 12-month warranty to be free of defects in materials and workmanship.

This warranty does not cover or include product finish, improperly installed or applied products, improperly maintained products, products or components used for racing or competition or damage due to abuse or neglect, products that fail due to the use of larger tire and wheel combinations.

All returns must be accompanied by an original invoice. It is the customer's responsibility to remove the product from the vehicle. Shipping charges are the responsibility of the customer. TeraFlex Inc. will pay the return freight if the product meets the terms of warranty.

This warranty is for the replacement or repair of defective TeraFlex products only and does not include freight charges, labor charges for removal of or installation of TeraFlex or related products or components, costs incurred due to down time of the vehicle, or lost profits due to vehicle down time.

A returned goods authorization number (RGA#) must accompany any returned products. For more information please contact a TeraFlex customer service representative.

### COPYRIGHT

©Copyright 2014. All rights reserved, TeraFlex Inc. Reproduction of this catalog and/or any of its contents without written permission is strictly prohibited.

TeraFlex® is a registered trademark of TeraFlex Inc. All trade names and logos including but not limited to TeraFlex, FlexArms, RockGuard, Monster, and LCG are protected by law and duplication of trade names and/or logos are strictly prohibited.

TeraFlex Inc. reserves the right to update, discontinue, redesign, modify finish, part number or component build parts if deemed necessary without written notice.

TeraFlex Inc., and any associated dealers are not responsible for misprints or typographical errors that may have inadvertently been made within this instruction sheet.

Jeep® and the Jeep® grill are registered trademarks of Fiat Chrysler Automobiles N.V., and have no affiliation with TeraFlex Inc.

**TERAFLEX**, Inc.  
5680 West Dannon Way  
West Jordan, Utah 84081  
Phone/801.713.3314  
Fax/801.713.2313  
www.teraflex.com