

INSTALLATION INSTRUCTIONS



MECHANICAL-TO-ELECTRICAL SPEEDOMETER VSS ADAPTER

301447-1-KIT

(FOR USE WITH TOYOTA MECHANICAL VEHICLE SPEED SENSORS IN TOYOTA VEHICLES EQUIPPED FOR ELECTRONIC VEHICLE SPEED SENSORS)

KIT CONTENTS





RECOMMENDED TOOLS

Flashlight

Adjustable Wrench

CAUTION

1. Read all instructions completely and carefully before you begin. If anything is not clear, please call our tech support line at 1.877.4X4.TOYS or 559.252.4950 before proceeding.
2. Check to make sure the kit is complete and that no parts are missing (refer to the Kit Contents Section on the first page of these instructions). If anything is missing, please contact Trail-Gear at 1.877.4X4.TOYS or 559.252.4950.
3. Park vehicle on a clean, dry, flat, level surface and block the tires so the vehicle cannot roll in either direction.
4. This kit is for off-road use only. It is recommended that the installation steps below be performed by a competent mechanic. Buyers and users of this product hereby expressly assume all risks associated with the installation and use of this kit.

INSTALLATION INSTRUCTIONS



TOYOTA VEHICLE INSTRUCTIONS

STEP 1

1. Make sure the threads of the Mechanical Vehicle Speed Sensor (VSS) are clean and undamaged.



STEP 2

2. Thread the Adapter onto the Mechanical VSS. Do not overtighten the Adapter.



STEP 3

3. Plug the Electronic VSS plug into the adapter.



STEP 4

4. Take the vehicle for a test drive. Verify correct speedometer operation.

INSTALLATION INSTRUCTIONS



ISUZU AMIGO, PICKUP, RODEO, TROOPER, HONDA PASSPORT, & ACURA SLX INSTRUCTIONS

STEP 1

1. This is a direct replacement for OEM P/Ns 8971188100, 8971297040, 8973779200, SU5426, 5S4595, & VSS21. Install per the Factory Service Manual for the Make, Model, & Year of your vehicle.

WIRING DIAGRAM

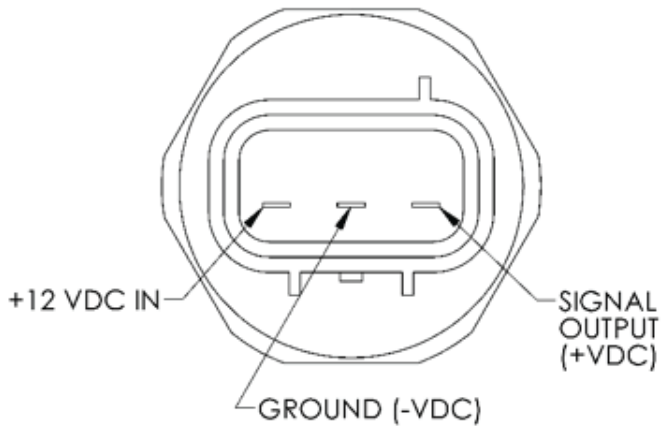

SERVICE PARTS:

